

Compact Sushi Forming / Wrapping Machine

SGP-SNB

This machine wraps each piece of sushi beautifully by film.

Wrapped sushi looks high quality, very clean and it actually keeps freshness by individual piece base which will excite customer's interest.



POINT

- The novel design which rice ball (Shari-dama) forming unit connected with film wrapping unit compactly.
- Keeps freshness to prevent the color changing of ingredient and drying sushi rice.
- Adoption of Easy-open film which is suitable wrapping sushi style for catering and take-out business.



Rice dividing and 1st forming



2nd forming (wasabi for option)



Topping manually



Wrapped sushi comes out automatically.

■Dimensions

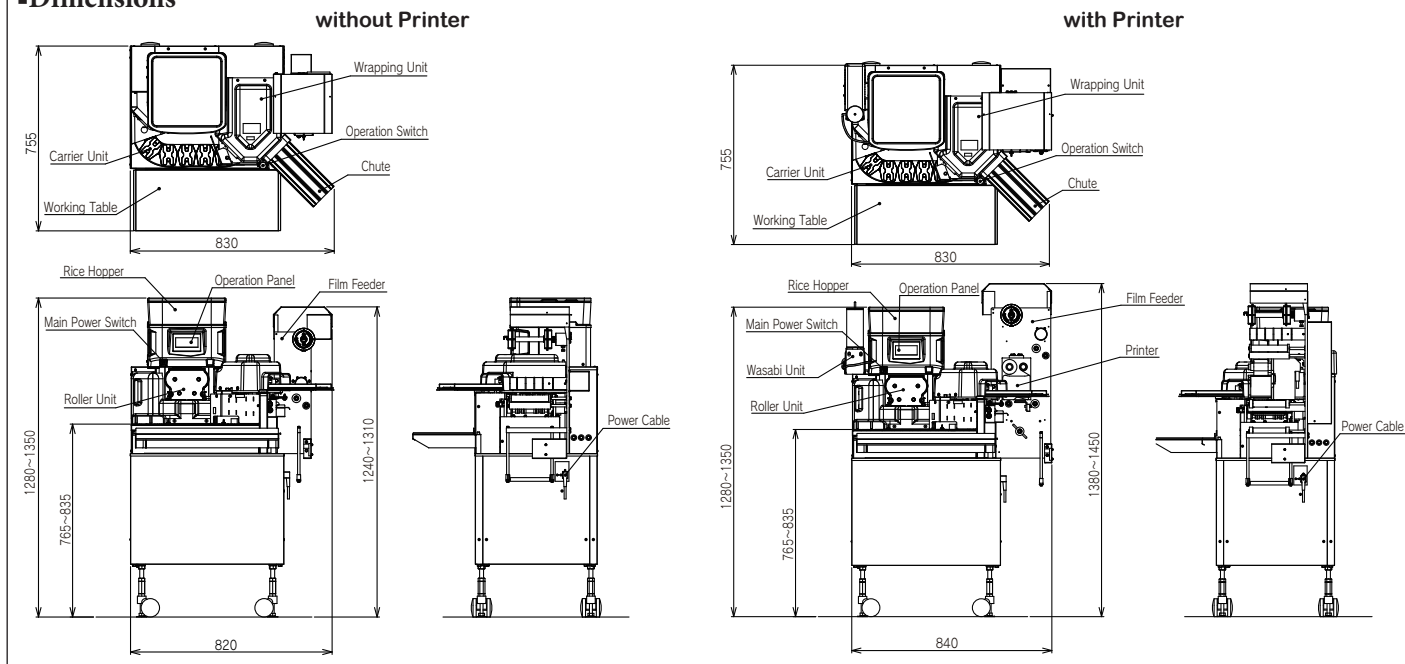

■Specification

Model

SGP-SNB-FT

Capacity

1000, 1200, 1400, 1600, 1800, 2000 pcs./hr. (selectable)

Dimension

830W×755D×1280-1350Hmm (without Printer)

840W×755D×1380-1450Hmm (with Printer)

Power

Single-phase, AC100-240V, 50/60Hz

Power Consumption

350W (without Optional Items)

450W (with Optional Items)

Rice Hopper Capacity

Approx. 6.5kg of cooked rice

Rice Ball Size

18, 20, 22, 25g (Selectable)

Wrapping Dimensions

68L×35W×30Hmm

Wrapping Film Specification

135mm width, 30μ thickness

Machine Weight

144kg (without Optional items)

Option

Printing Unit, Wasabi Unit, Printer, Sub Hopper

■Features

- 2 in 1 design (Sushi Forming & Wrapping).
- Fluffy perfect rice ball are made by Suzumo innovative technology.
- User Friendly LCD touch panel.
- Easy to assemble/disassemble food contacting parts for cleaning.
- Just pull both sides of film to enjoy the Sushi (Patented).

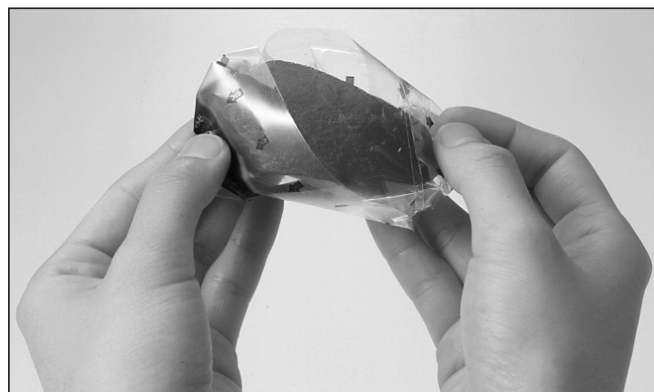

* Capacity expresses the machine's performance capability.
The actual result may vary depending on the operator.

*Designs and specifications subject to change without notice.

Suzumo Machinery Co., Ltd. Global Business Division

2-23-2, Toyotamakita, Nerima-ku, Tokyo 176-0012, Japan

Tel. +81 3-3993-1407 Fax. +81 3-3993-1756

e-mail overseas@suzumo.co.jp URL <http://www.suzumokikou.com>

< Contact in North America >

Suzumo International Corporation

Head Office : 1815 W. 205th Street, Suite 101 Torrance, CA 90501 U.S.A.

Tel. +1 310-328-0400 Fax. +1 310-328-2700 e-mail sic@suzumokikou.com

East Office : 560 Sylvan Avenue, Suite 2020 Englewood Cliffs, NJ 07632 U.S.A.

Tel. +1 201-568-1900 e-mail sic@suzumokikou.com

< Contact in Singapore >

Suzumo Singapore Corporation Pte. Ltd.

421 Tagore Industrial Avenue #04-11 Tagore 8, Singapore 787805

Tel. +65 6254-2080 Fax. +65 6254 2086 e-mail sales@suzumo-sg.com